

# GLASS IS LIFE™

**O-I** makers of pure, sustainable,  
brand-building glass packaging

## O-I Manufacturing France

64 bd du 11 Novembre 1918 - BP 1228  
69611 Villeurbanne Cedex, France  
Tel. +33 (0)426686500

### CONTAINER & MOULD ENGINEERING EUROPE

NOTES:  
THIS DRAWING IS THE PROPERTY OF O-I AND  
MUST NOT BE REPRODUCED OR DISCLOSED  
WITHOUT O-I WRITTEN AUTHORIZATION.

ONLY TOLERANCED DIMENSIONS ARE GUARANTEED.

MANUFACTURING MARKINGS SHOWN ARE FOR ILLUSTRATIVE  
PURPOSES ONLY, ACTUAL MARKINGS ON CONTAINER  
MAY DIFFER, DEPENDANT ON LOCAL LEGISLATION.

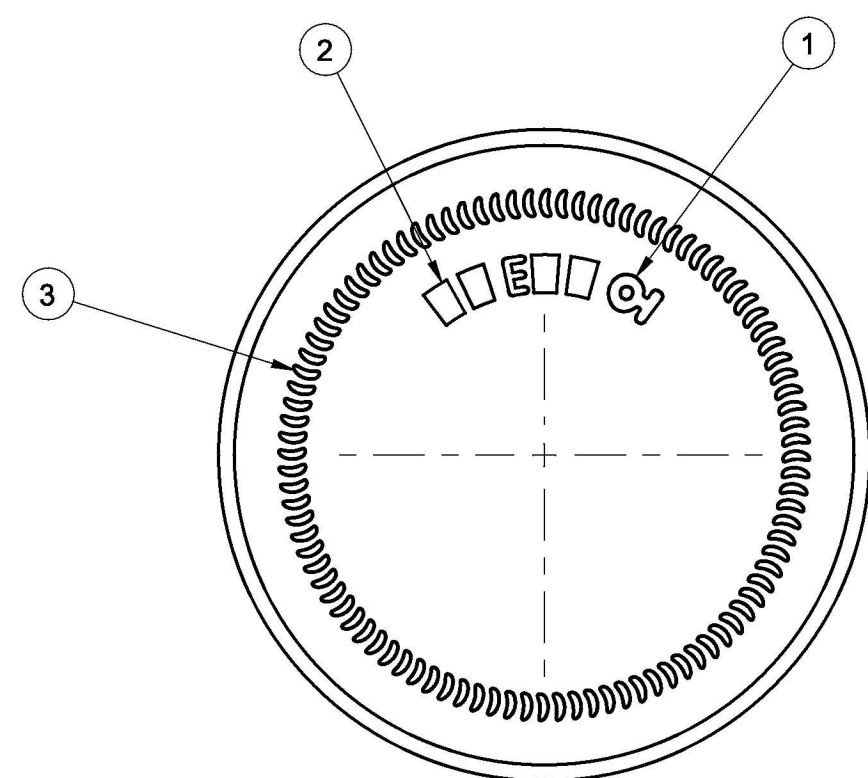
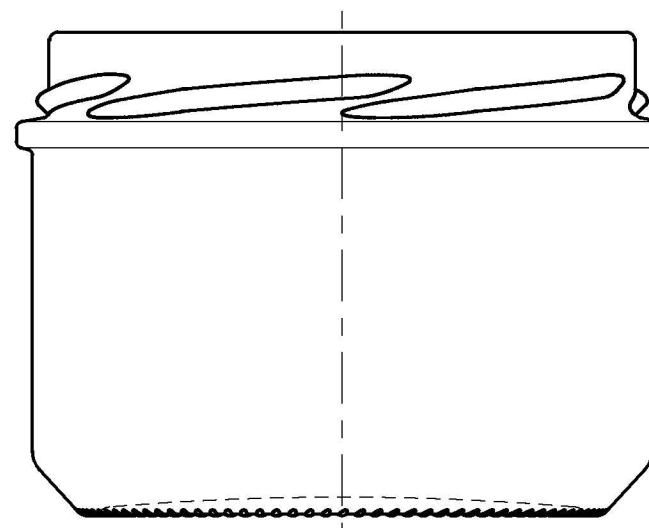
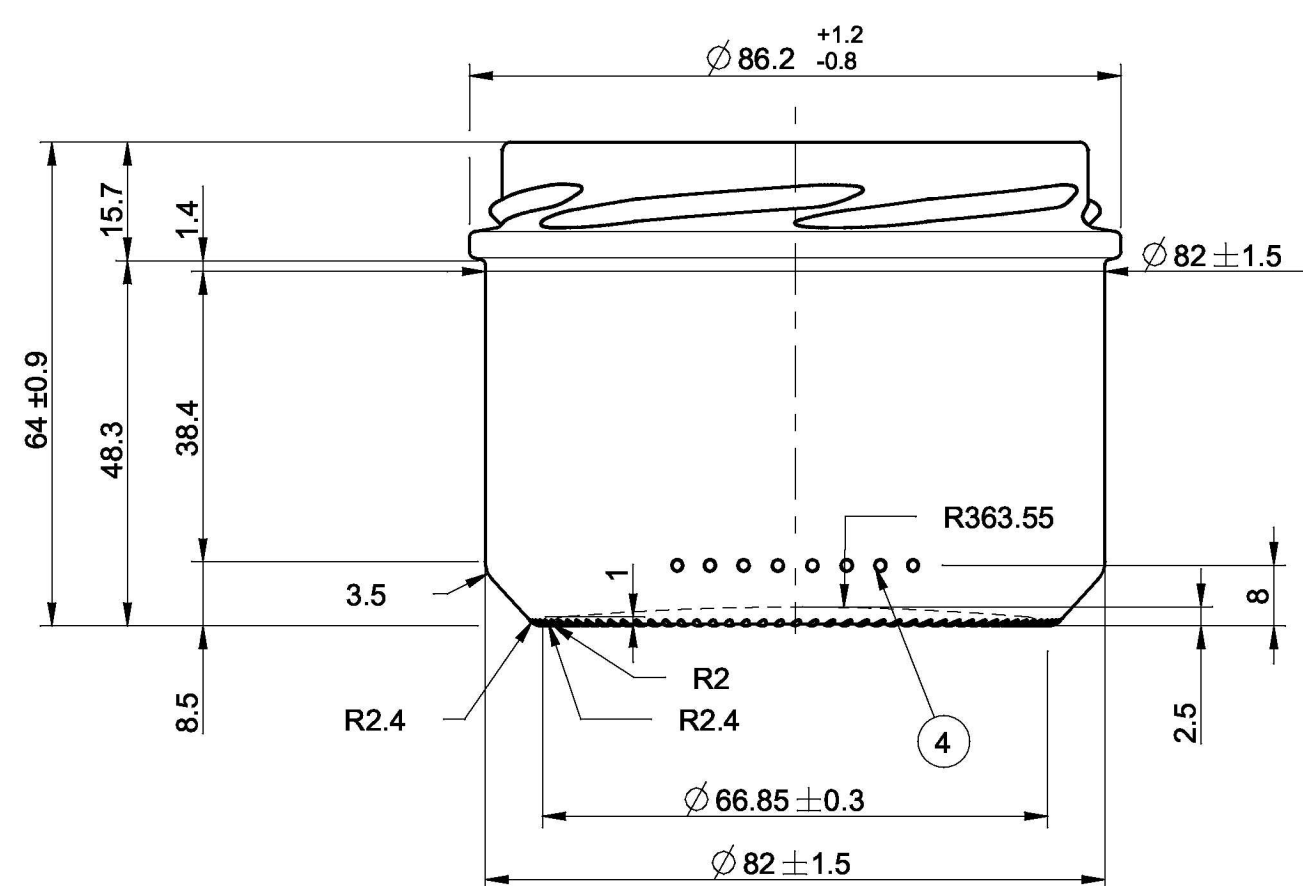

1 = TRADEMARK  
2 = CAVITY No.  
3 = STIPPLING  
THE SHAPE OF STIPPLES IS ONLY AN  
INDICATION AND THE CONSTRUCTION IS AT  
THE PRODUCTION PLANT DISCRETION.  
4 = CAVITY CODE

SCALE 1:1

HEAT TREATMENT XX °C maxi	CARBONATION XX g CO2/l maxi
VERTICAL LOAD 150 daN maxi	THERMAL SHOCK 42 °C maxi
CATEGORY FOOD	TILT ANGLE 47.98°
MAX. VERTICALITY TOLERANCE 1.5 mm	MEASURING CONTAINER NO
FINISH SAP NUMBER 3781	FINISH REF. CETIE GME 20-09 1995
MINIMUM THROUGH BORE mm	MAX FILLING TUBE Ø mm

CONTAINER OVERFLOW CAPACITY (BRIMFUL)  
262ml ± 6ml

CONTAINER RATED CAPACITY (FILLPOINT)

CONTAINER WEIGHT  
145g APPROX.

FINISH DESIGNATION  
FR\_82\_GME 20-09\_H157\_3781

MAX GAS VOLUME  
PROCESS RETURNABLE NO DESIGN REF. IPSO 3665

### STANDARD 262 ML POT STD TO 82

DESIGNER	T LORNAME	DATE	28/12/12
CHECKED		DATE	
DRAWING NUMBER 120904	MOULD/SAP NUMBER 120904		

No	DATE	REVISIONS	DESIGN/CHECK
	04/03/13	CREATION	BCO