

GLASS IS LIFE™

O-I makers of pure, sustainable,
brand-building glass packaging

O-I Manufacturing Netherlands B.V.

Postbus 46
3100 AA Schiedam, Netherlands
Tel. tel. +31 0104094444

CONTAINER & MOULD ENGINEERING

EUROPE

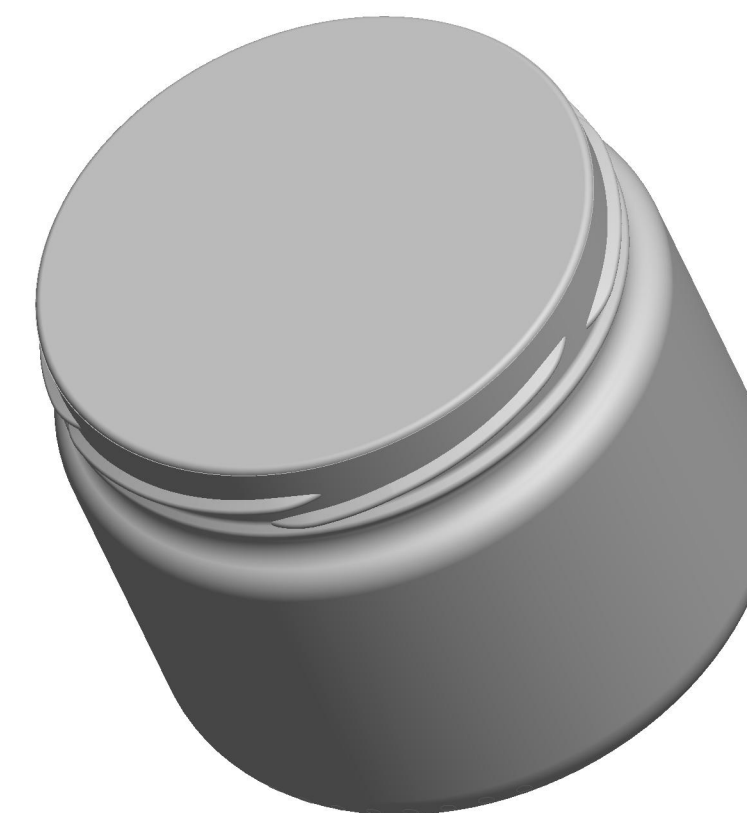
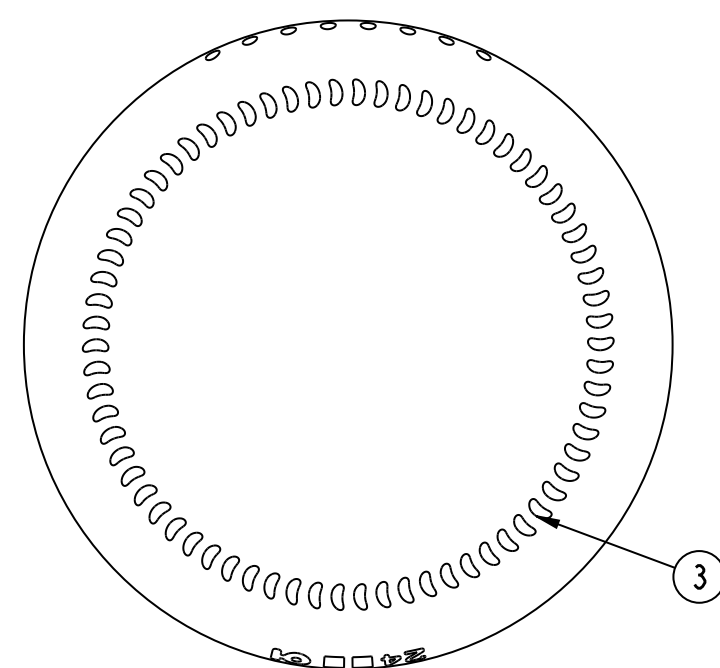
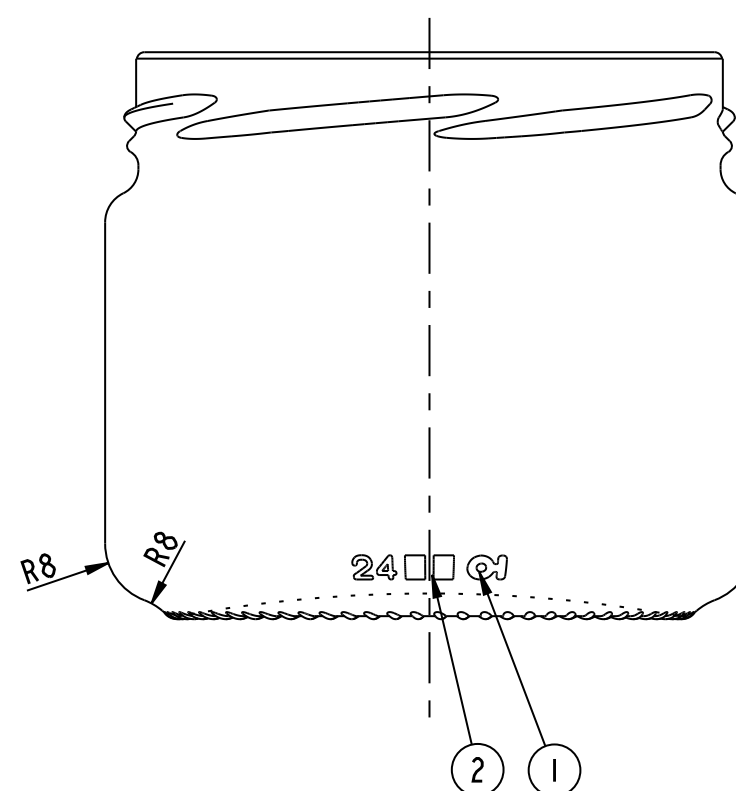
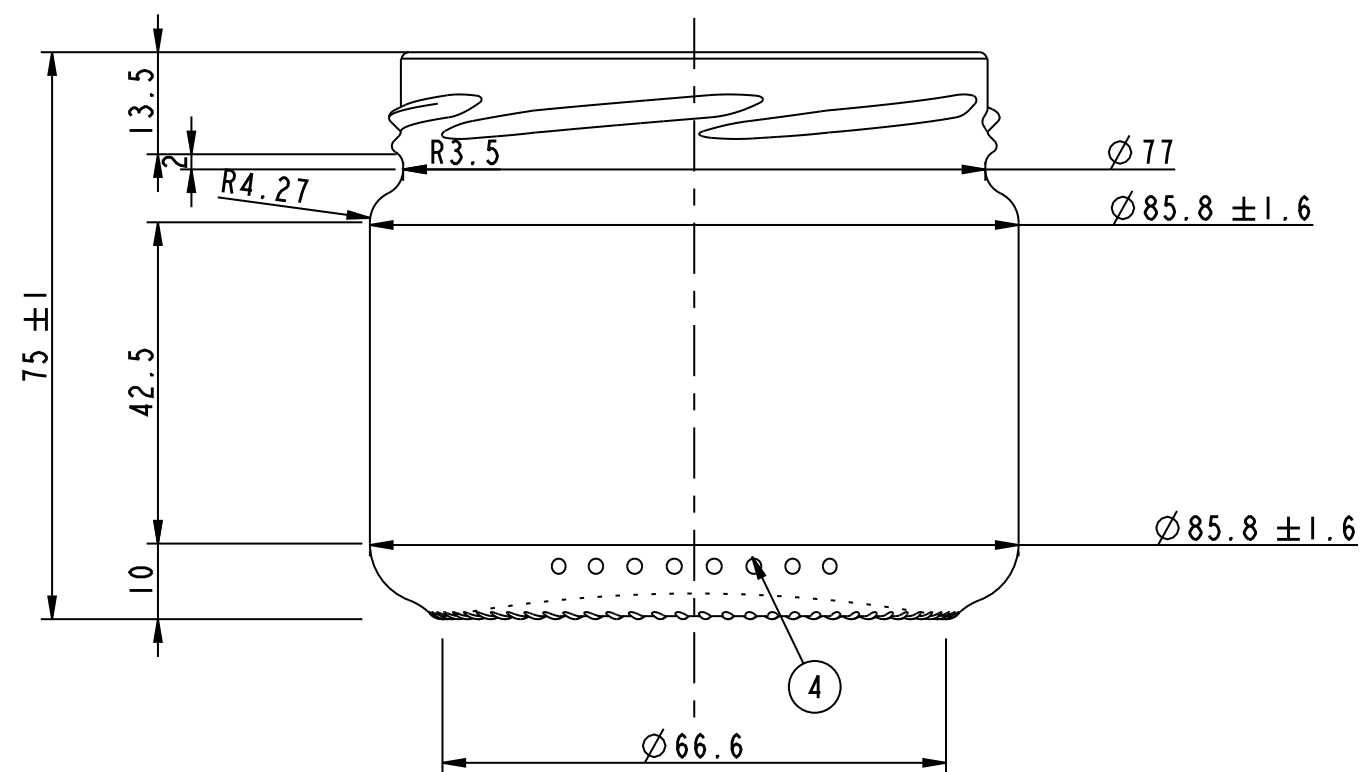

NOTES:
THIS DRAWING IS THE PROPERTY OF O-I AND
MUST NOT BE REPRODUCED OR DISCLOSED
WITHOUT O-I WRITTEN AUTHORIZATION.

DIMENSIONS EXPRESSED IN mm
ONLY TOLERANCED DIMENSIONS ARE GUARANTEED.

MANUFACTURING MARKINGS SHOWN ARE FOR ILLUSTRATIVE
PURPOSES ONLY, ACTUAL MARKINGS ON CONTAINER
MAY DIFFER, DEPENDANT ON LOCAL LEGISLATION.

CATEGORY FOOD		TILT ANGLE 44.4°	
MAX. VERTICALITY TOLERANCE 1.5 mm		MEASURING CONTAINER YES	
FINISH SAP NUMBER 0542		FINISH REF. SPECIAL	
MINIMUM THROUGH BORE 71.8 mm		MAX FILLING TUBE Ø 1 mm	
CONTAINER OVERFLOW CAPACITY (BRIMFUL)			
333ml ± 3,5ml			
CONTAINER RATED CAPACITY (FILLPOINT)			
CONTAINER WEIGHT			
172g APPROX.			
FINISH DESIGNATION NL_82_SPECIAL_HI35_0542		MAX GAS VOLUME	
PROCESS	RETURNABLE NO	DESIGN REF.	

**Standard item
333 ml Jar**

DESIGNER	MH	DATE	23/02/12
CHECKED		DATE	
DRAWING NUMBER 120137		MOULD/SAP NUMBER 003240	

1 = TRADEMARK
2 = CAVITY No.
3 = STIPPLING
THE SHAPE OF STIPPLES IS ONLY AN
INDICATION AND THE CONSTRUCTION IS AT
THE PRODUCTION PLANT DISCRETION.
4 = CAVITY CODE

SCALE 1:1

No	DATE	Design was 2344-07	REVISIONS	DESIGN/CHECK